

Mechanical:

REV.	ECN NO.	DESCRIPTION	DATE	APPD
A	REL		2013/07/08	

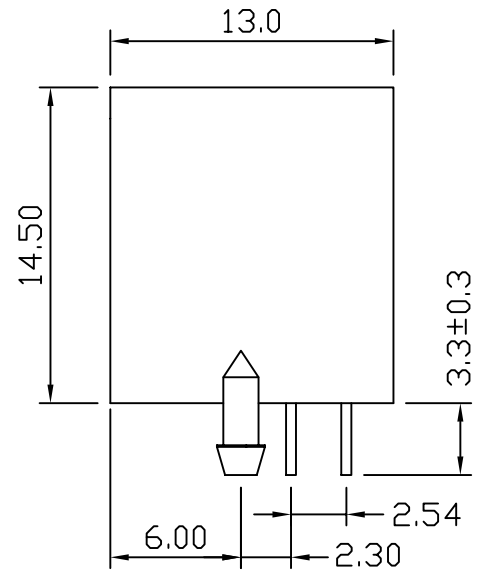
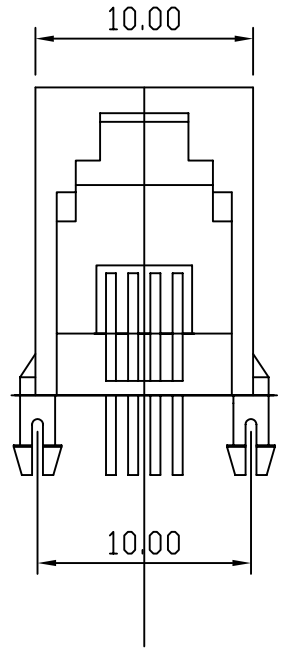

MATERIAL:

- 1. INSULATOR BODY : THERMOPLASTIC UL94V-0
- 2. CONTACT : 30U" GOLD PLATING
- 3. SPRING WIRE : ∅0.45mm PHOSPHORBRONZE, GOLD PLATING OVER NICKEL

ELECTRICAL DATA:

- 1. RATED CURRENT : 1.5A
- 2. VOLTAGE RATING : 150VAC MAX
- 3. CONTACT RESISTANCE : 30MΩ MAX
- 4. INSULATION RESISTANCE : 500MΩ MIN
- 5. WITHSTANDING VOLTAGE : 1000V AC FOR 1min.
- 6. (1)Storage: -40°C to +85°C
- (2)Operation: -40°C to +85°C
- (3)Wave solder temperature:230°C to 250°C, 5~10 Sec.

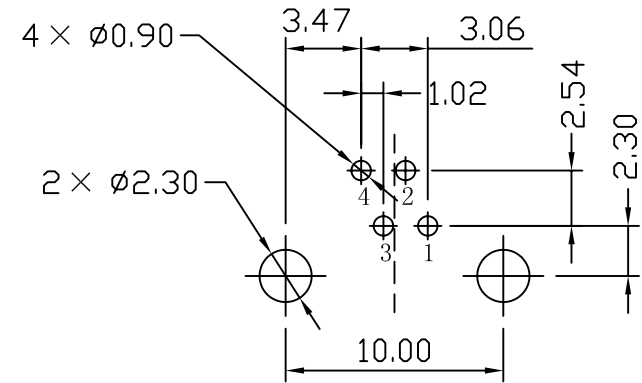
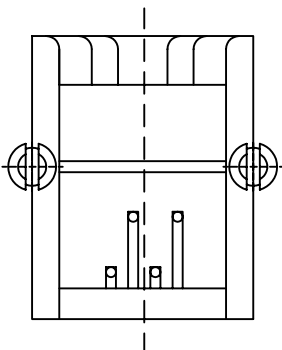

PC Board Layout (Top View)

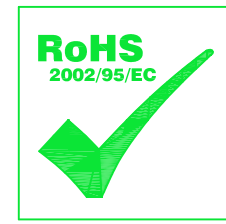

X:X ±0.25	APPD:	LINK-PP INT'L TECHNOLOGY CO., LIMITED		
X:XX ±0.20	CHKD:	TITLE: RJ11 1×1 CONNECTOR (4P 4C)		
X:XXX ±0.10	DR: TOM	PART NO.: LPJE8013NNL		
ANGLES ±1°	UNIT: mm			
	SCALE: 2/1	SHEET: 1/1	REV: A	DWG NO.: LP13070805